TECHNICAL DATA SHEET

MT 1840

Manitou Telescopic



 **MANITOU**
HANDLING YOUR WORLD

	MT 1840	MT 1840 A	MT 1840 HA
Lifting			
Max. capacity		4000 kg	
Max. lifting height		17.55 m	
Max. outreach		13.08 m	
Break-out-force with bucket (iso 8313)		8150 daN	
Unlading time			
Lifting	16.0 s		14.0 s
Lowering	12.0 s		14.0 s
Extension	16.0 s		19.0 s
Retraction	13.0 s		15.0 s
Crowd	4.0 s		5.0 s
Dump	4.0 s		5.0 s
Tyres	440 / 80 -24		
Braking			
Service brake	oil immersed multidisc braking on front and rear axles		
Parking brake	automatic negative parking brake		
Engine			
	PERKINS - STAGE 4 - FINAL TIER 4		
Type	854F-E34TA		
Power	100 HP / 75 kW		
Max torque	430 Nm		
Injection	electronic		
Cooling	water		
Laden drawbar pull	10300 daN		7300 daN
Transmission			
	torque converter		hydrostatique
Reversing shift	electrohydraulic control		
Number of gears (forward/reverse)	4/4		
Drive wheels	4 wheel drive		
Steering mode	4 wheel steer - 3 steering modes		
Max. travel speed (may vary according to applicable regulations)	25 or 35 kph		
Hydraulics			
Pump	gear type with priority valve 170 l/min – 270 bar		
Capacities			
Hydraulic oil	135 l		
Fuel	140 l		
Unladen weight	11 800 kg		12000 kg
Dimensions			
1. Front wheel centre to carriage	2.04 m		
2. Ground clearance	0.42 m		
3. Overall length to carriage	6.27 m		
4. Wheelbase	3.07 m		
5. Rear wheel centre to rear face	1.16 m		
6. Overall width of cab	0.89 m		
7. Inside tyre width	1.96 m		
8. Overall width	2.42 m		
9. Overall width (stabilizers lowered)	3.79 m		
10. Overall height	2.50 m		
Turning radius (over tyres)	4.01 m		
Carriage rotation (crowd / dump)	12° /114°		
Standard forks (length x width x thickness)	1200 x 125 x 50 mm		
Frame levelling	in standard		
Controls			
	JSM [*] (Multi-function joystick)		
Safety			
	Load limiter cut off system - EN 15000 norm ROPS FOPS level II standard cab		
Noise and vibrations			
Noise at driving position (LpA)	78 dB		
Environmental noise (LwA)	103 dB		
Vibration to whole hand/arm	<2.50 m/s ²		

Rough terrain load chart
Standard EN1459 B

Machine on tyres with forks
LC 500 mm
(with frame levelling)

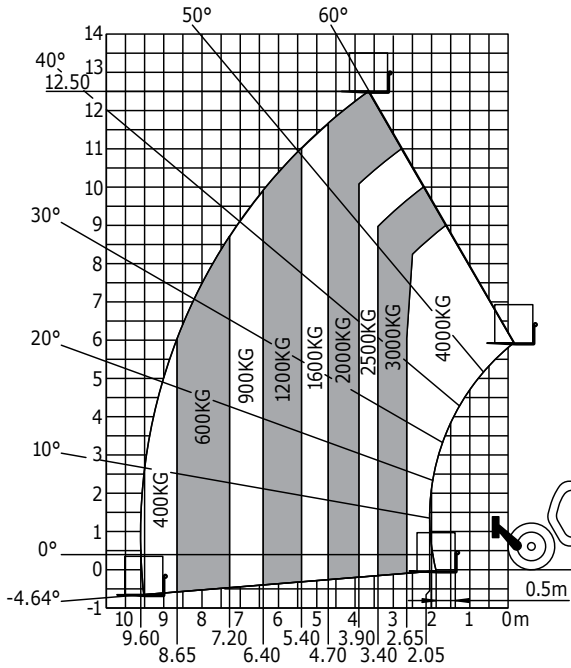

Machine on stabilizers with forks
LC 500 mm

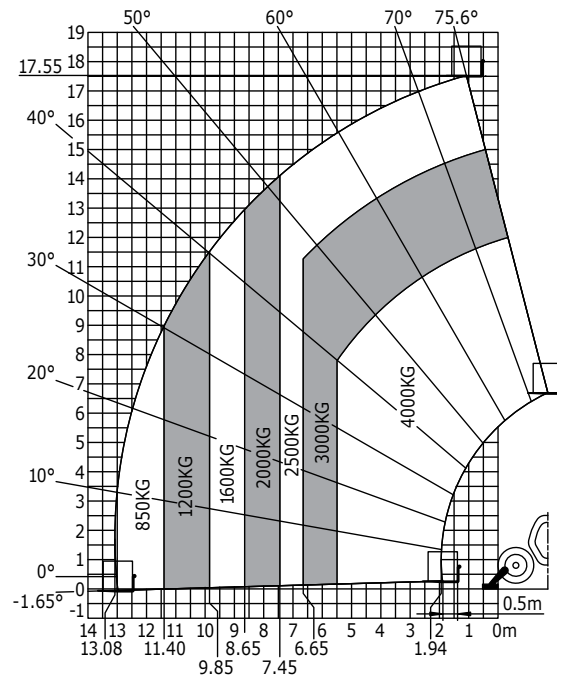

Machine with platform on stabilizers
(MT 1840 A - HA versions)

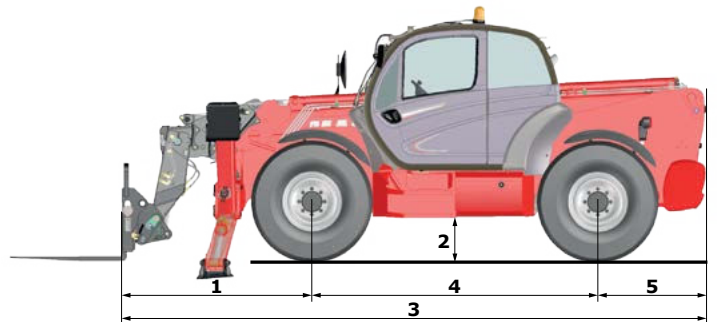
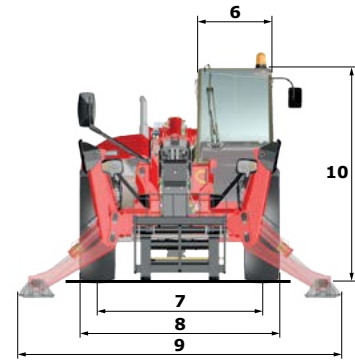
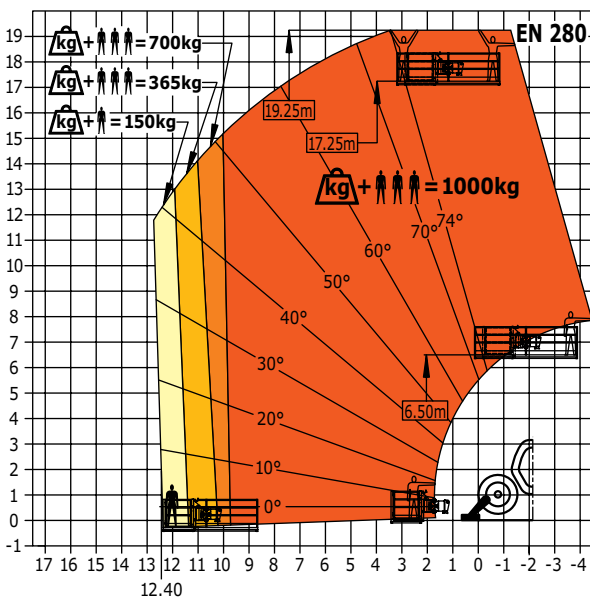

Your MANITOU dealer



Head office :
B.P. 249 - 430 rue de l'Aubinière - 44158 Ancenis Cedex - France
Phone.: +33 (0)2 40 09 10 11 - Fax: +33 (0)2 40 09 10 97
www.manitou.com

